

PATENT SPECIFICATION



Application Date : Dec. 6, 1934. No. 35031/34.

448,437

Complete Specification Left : Dec. 6, 1935.

Complete Specification Accepted: June 8, 1936.

PROVISIONAL SPECIFICATION

Improvements in or relating to Slicing Machines

We, BERKEL & PARNALL'S SLICING MACHINE MANUFACTURING COMPANY LIMITED, of Aden Road, Ponders End, Middlesex, England, a British Company, do hereby declare the nature of this invention, which has been communicated to us by Maatschappij van Berkel's Patent N.V. of 33, Boezemsingel, Rotterdam, Holland, a body corporate organised under the Laws of Holland, to be as follows:—

This invention relates to slicing machines of the type in which the substance to be sliced is or can be fed forwards step-by-step by a mechanical feed and in which a gauge device is provided to permit accurate preliminary positioning of the substance or to afford an alternative means of controlling the slice-thickness.

The gauge device usually consists of a platelike member with a substance-contacting face disposed when in use behind and parallel to the slicing plane of the knife, the said member being adjustable to vary the distance between said face and said plane to accord with the required slice-thickness.

In previously proposed machines of the type stated, a single adjustment knob is provided in operative association with both the feed mechanism and the gauge device, the arrangement being such that both are adjusted simultaneously to the same extent when the knob is manipulated to alter its slice-thickness setting. A disadvantage of this arrangement is that mechanical connections must be provided not only between the knob and the feed-mechanism but also between the knob and the gauge device, thus adding proportionately to the expense of the machine and involving the need for imparting a comparatively great adjustment force.

The object of this invention is to remove the aforesaid disadvantages of the previously proposed constructions, this object being realised by providing in a slicing machine of the type stated feed-mechanism which is adjustable independently of the gauge device to vary the slice-thickness, and making

provision for cooperation between said mechanism and said device as regards the extent of their adjustment. 55

The aforesaid provision preferably consists in mounting the gauge device in such a manner that it resists displacement away from the slicing plane but yields (or can be set to yield) when subjected to a force in excess of a predetermined limit force. The arrangement is such that the gauge device can be set by hand in its zero position (i.e. with its face disposed in the slicing plane) preparatory to a series of slicing operations and the substance properly positioned against the gauge face and clamped on the feed-table or other substance-carrier. No slice will be cut in the first "slicing" stroke of the machine. About the end of the first "return" stroke the substance-carrier receives a forward displacement force from the feed-mechanism, and consequently the substance pushes the gauge-device to the extent of the feed movement away from the slicing plane. The series of slicing operations can now be performed, and following the conclusion of said operations the gauge device can be re-set in its zero position. 60 65 70 75 80

The preferred mounting of the gauge device includes a frictional connection between it and its support on the machine frame. 85

In one construction according to the invention, the gauge device is provided in association with ratchet-and-pawl feed mechanism whose pawl-carrier as usual cooperates with a feed-bar adjustably mounted on the machine frame and adapted to cooperate with a slice-thickness-indicating graduated scale. The gauge-device comprises a plate which may have any suitable support: e.g. it may be carried by a guide or guides slidable in bearings on the machine frame; or it may be carried by one or more pivotal arms borne by parts on the machine frame. A frictional connection is provided at any suitable place in the supporting connection between the gauge plate and the machine frame: e.g. between the guide or guides and bear- 90 95 100 105

[Price 1/-]

[This Drawing is a reproduction of the Original on a reduced scale.]

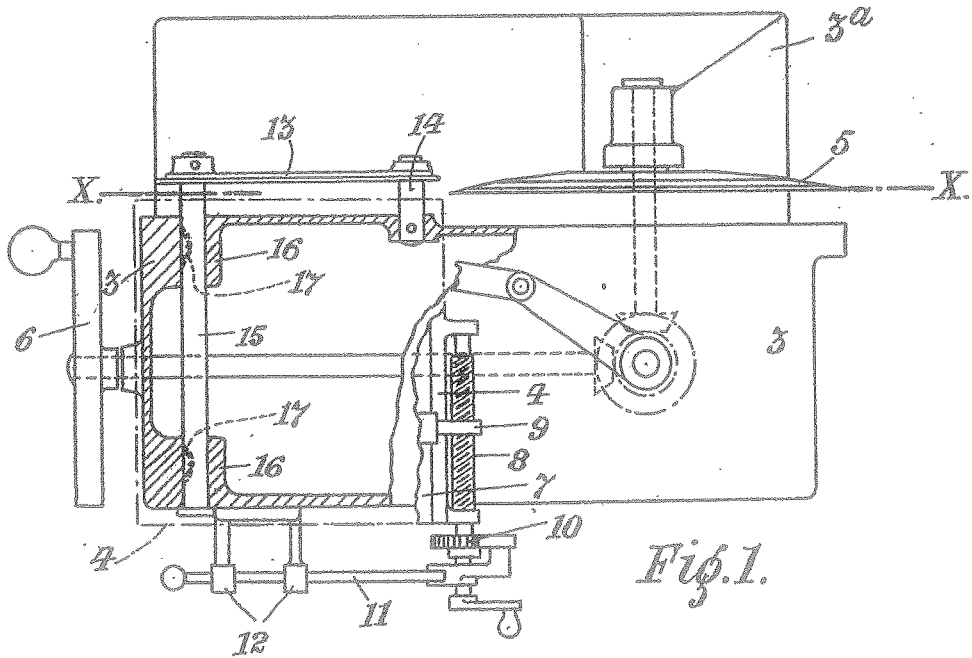

Fig. 1.

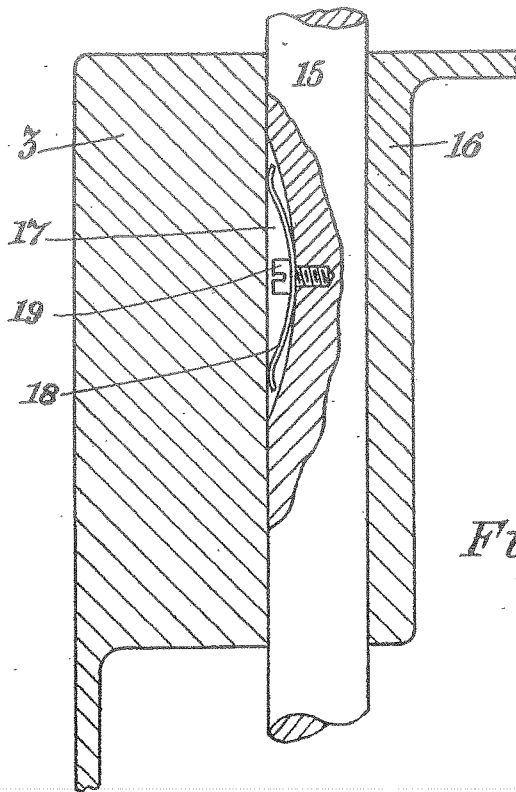

Fig. 2.

Malby & Sons, Photo-Lith.