

PATENT SPECIFICATION

435,338

Application Date : July 13, 1934. No. 20549/34.

Complete Specification Accepted : Sept. 19, 1935.



COMPLETE SPECIFICATION

Improvements relating to Slicing Machines

We, BERKEL & PARNALL'S SLICING MACHINE MANUFACTURING COMPANY LIMITED, a British Company, of Aden Road, Ponders End, Middlesex, England, and HENRY THOMAS, a British subject, of the Company's address, do hereby declare the nature of this invention and in what manner the same is to be performed, to be particularly described and ascertained in and by the following statement:—

Machines for slicing meat and other edible substances are commonly provided with a conveniently attachable and detachable fitting known as an end-piece holder, the function of which is to grip comparatively short pieces of substance, usually end pieces, that cannot be conveniently clamped or otherwise secured in place. End-piece holders are attachable to a slicing-machine part adapted to receive feed-movements (and hereinafter referred to in general as "feed-part") towards the slicing knife, and they are usually provided with prongs which can be turned so as to penetrate the substance and hold it securely against the face of the holder.

It is known to provide a slicing machine with an end-piece holder mounted on a support in such a manner as to be angularly adjustable relatively to the feed-part and to provide means for imparting to the holder an automatic angular motion as it feeds the substance forward during slicing thereof. A slicing machine with such provision is capable of slicing approximately wedge-shaped pieces without substantial waste, the effect of the angular motion being that a succession of more or less slightly tapered slices are cut.

The object of the present invention is to provide improved means for imparting angular motion to end-piece holders. In accordance with the invention, the improved means comprises a lever device fulcrumed at one side of the machine on the support of the end-piece holder and mechanically connected to said holder, said device in the forward movement of the support due to the slicing-machine feed co-operating as a striker with a separate abutment arranged at the said

side of the machine and receiving from said abutment due to its contact therewith a step-by-step angular motion which said device transmits to the holder through the intermediary of its mechanical connection therewith. The holder is held against inadvertent angular motion, for example by means of a friction device having provision for regulation of its frictional grip.

As a rule, the end-piece holder would be mounted for both clockwise and counterclockwise motion. An abutment adapted to impart such motion may consist of two oppositely inclined faces which are alternatively operative on the striker in accordance with the initial setting of the end-piece holder.

In a preferred construction, the lever device is arranged to fulcrum about a horizontal axis, and the mechanical connection between the lever device and the end-piece holder comprises a universal-joint member. This construction permits the said device and its associated parts to be located compactly at one side of the usual feed-table of the machine, or other feed-part. The universal-joint member may have a sliding ball or equivalent joint with one of the parts which it mechanically inter-connects.

The compactness of the arrangement may be augmented by mounting the holder in a support provided at one side with means of attachment to a feed-part, which means are capable when attached of completely supporting the holder and its support. In addition, the holder support may be provided with locking means which automatically acts to lock it to the feed-part on attachment of the support thereto.

Although the preferred construction of means for imparting angular motion comprises a two-armed lever device, such as a bell-crank-lever, having a horizontal fulcrum and cooperating with an inclined-faced abutment, various modifications of this construction can be made. For example, in one modification, a double lever device is employed, each lever having a mechanical connection through a universal-joint member

[Price 1/-]

PRICE 4S 6D

[This Drawing is a reproduction of the Original on a reduced scale.]

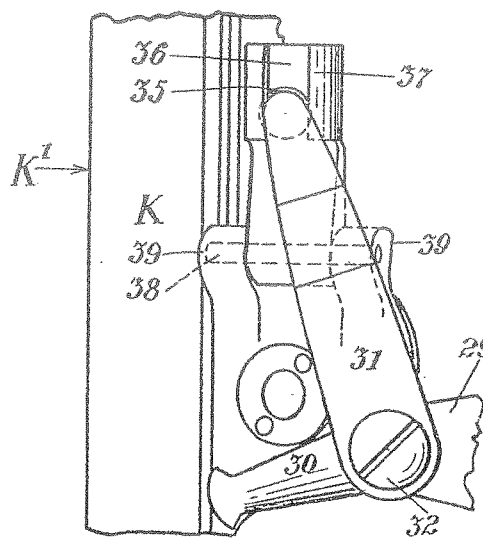
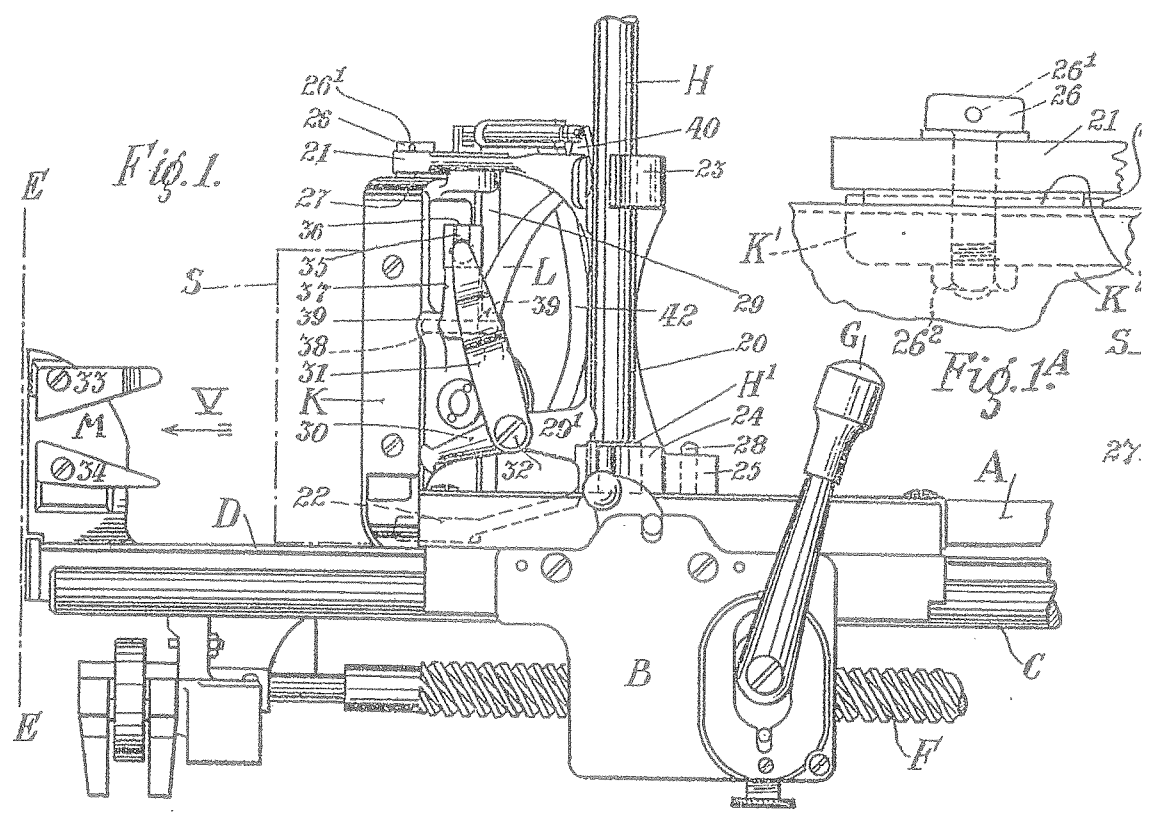

Fig. 3.

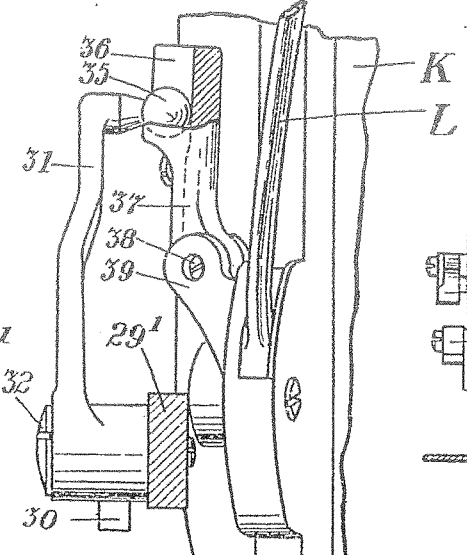
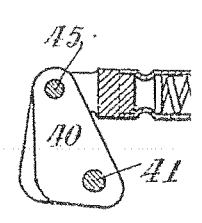
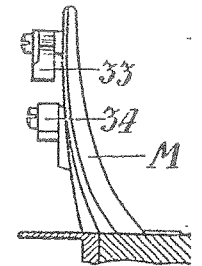
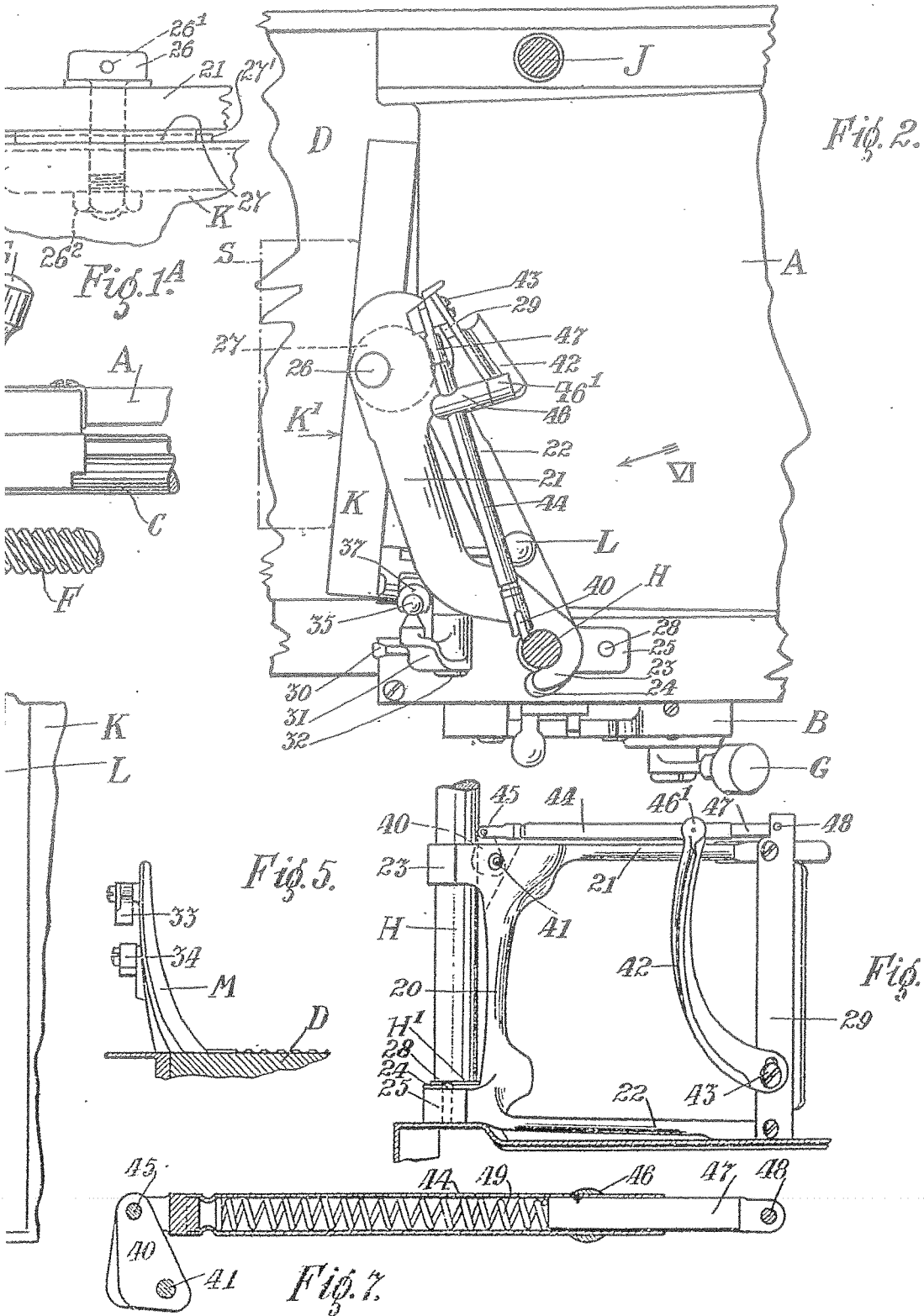
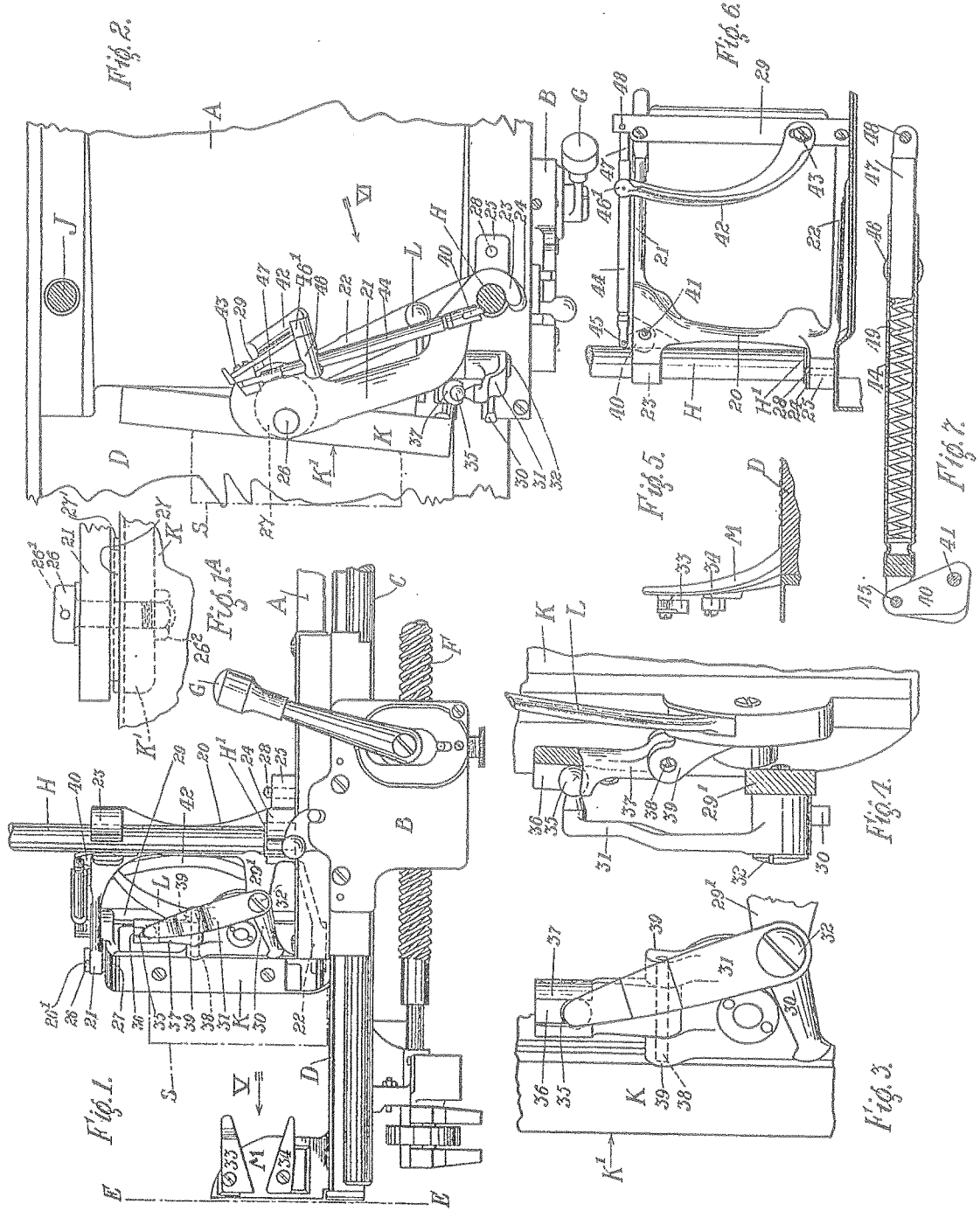

Fig. 4.





Malby & Sons, Lith.



[This Drawing is a reproduction of the Original on a reduced scale]

Fig. 8.

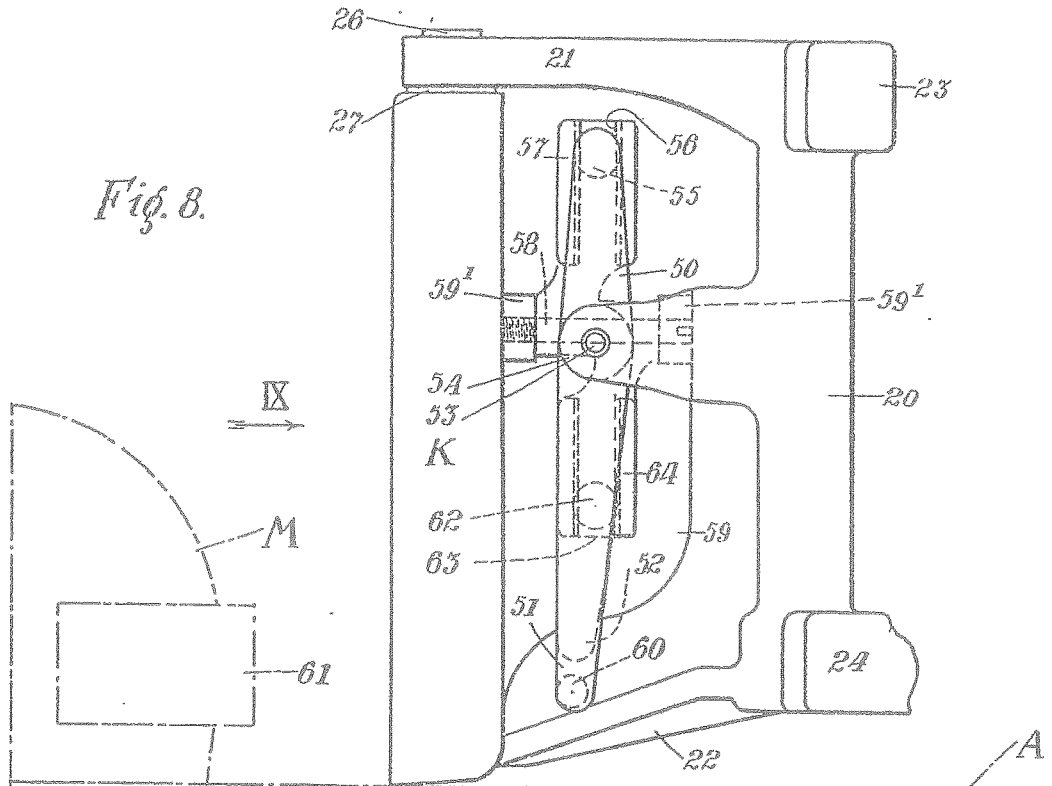
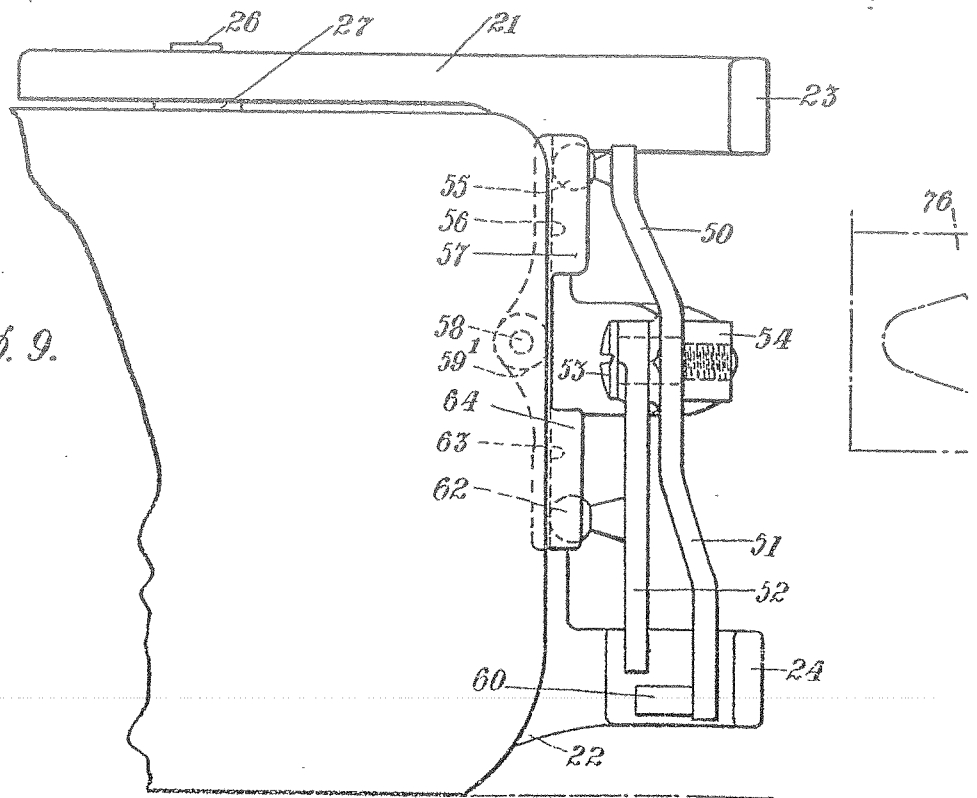
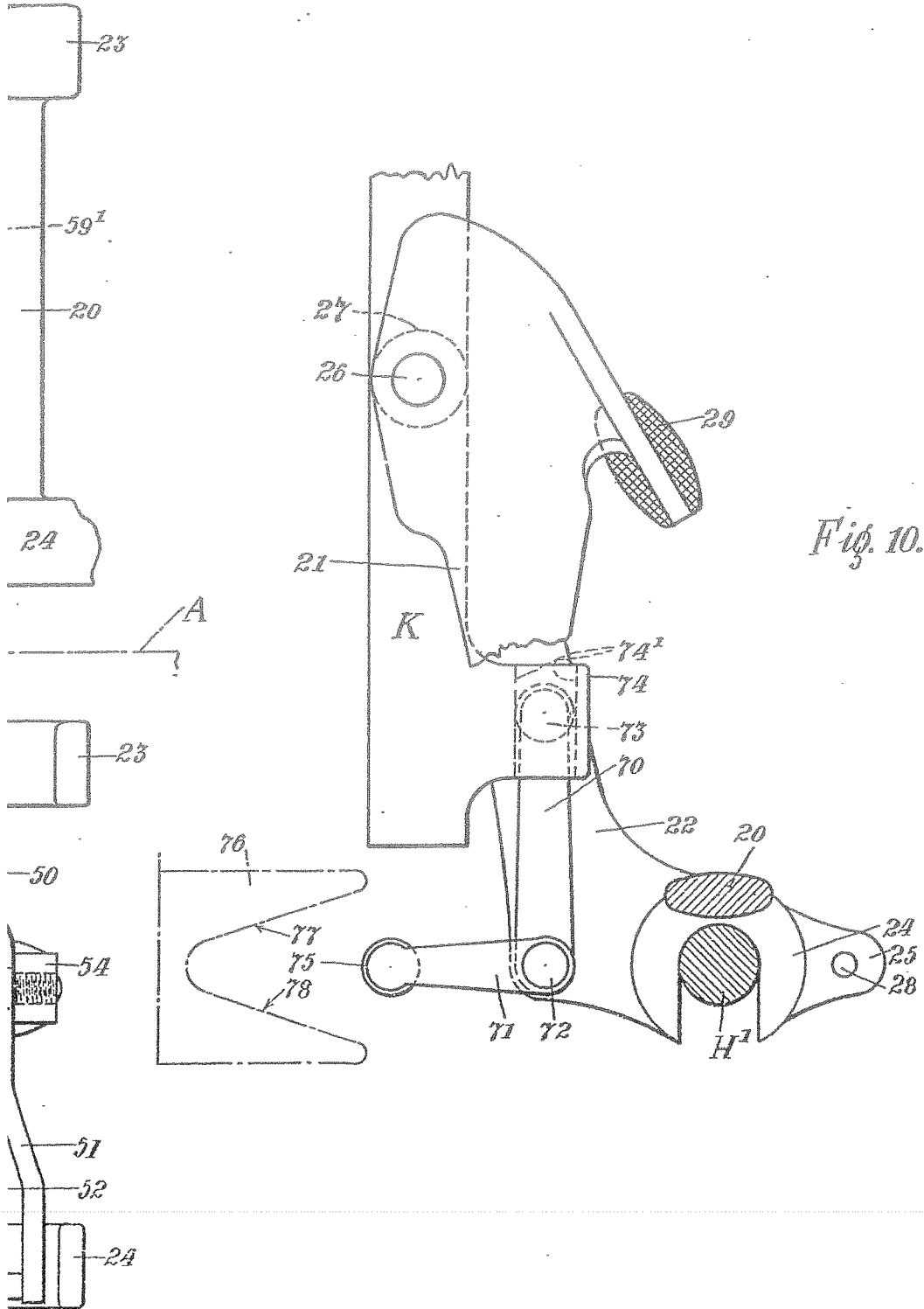

Fig. 9.



[This Drawing is a reproduction of the Original on a reduced scale.]



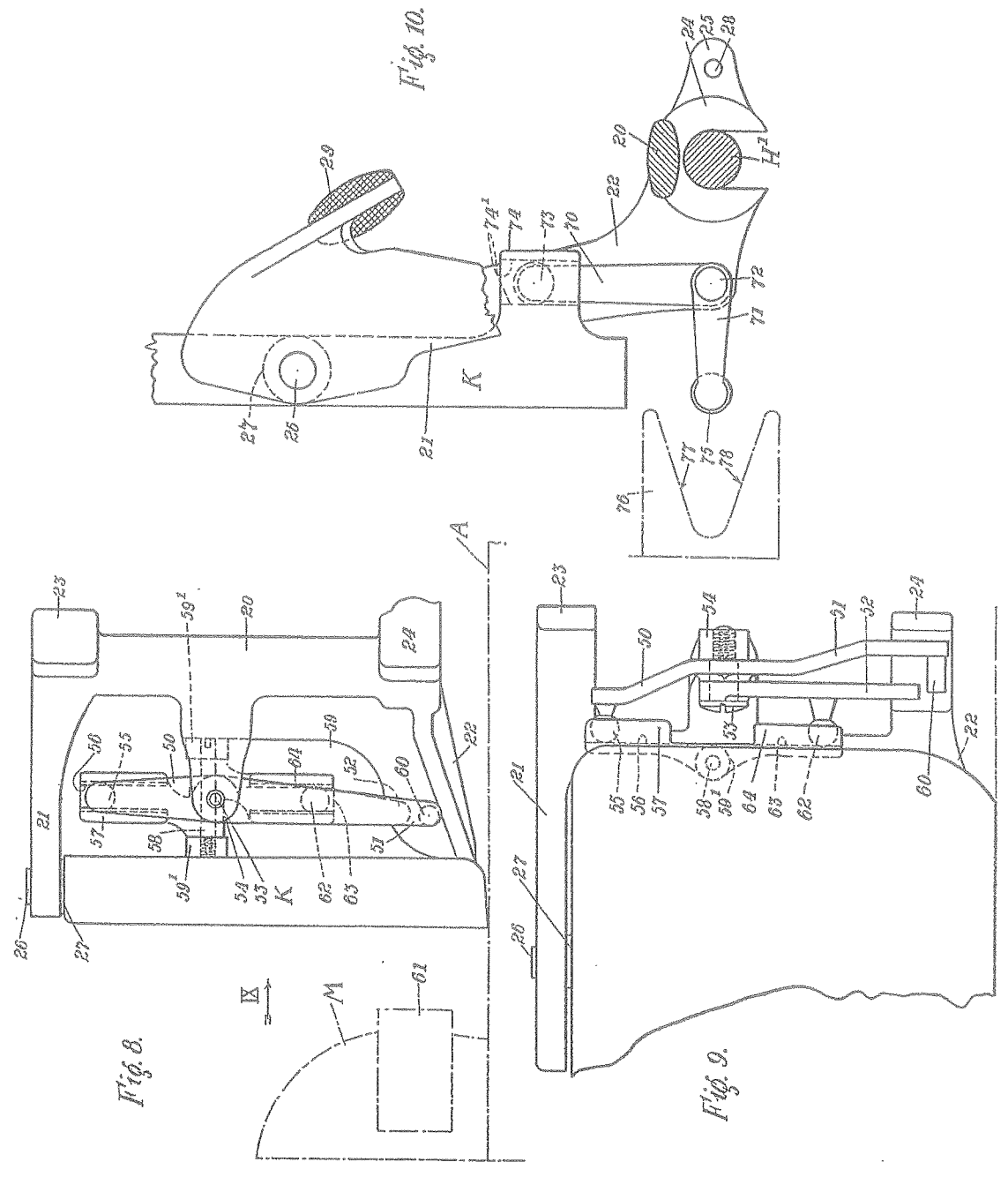

Fig. 8.

Fig. 9.

Fig. 10.

[This Drawing is a reproduction of the Original on a reduced scale.]