

Application Date : Oct. 6, 1934. No. 28658/34.

Complete Specification Accepted : March 3, 1936.



COMPLETE SPECIFICATION

Improvements in Slicing Machines

We, BERKEL AND PARNALL'S SLICING MACHINE MANUFACTURING COMPANY LIMITED, of Aden Road, Ponders End, Middlesex, England, a British company, do hereby declare the nature of this invention, which has been communicated to us by MAATSCHAPPIJ VAN BERKEL'S PATENT N.V. of 33 Boezemsingel, Rotterdam, Holland, a body corporate organised under the laws of Holland, and in what manner the same is to be performed, to be particularly described and ascertained in and by the following statement:—

This invention relates to machines for cutting meat and other edible substances into slices in succession, such machines being of the reciprocatory-carriage type in which the substance to be sliced is or can be fed forward step-by-step across the carriage by a mechanical feed and in which a gauge device is provided on the stationary machine-base to permit accurate preliminary positioning of the substance on the carriage or to afford an alternative means of controlling the slice thickness.

In machines of the type stated, it is customary to make provision whereby the feed mechanism and the gauge device can be adjusted to give any desired slice-thickness; and it is known to arrange the said mechanism and device in mechanical association so that, by manipulating a single means of adjustment, both the mechanism and the device are adjusted simultaneously and to the same extent.

The object of the present invention is to provide a simplified yet efficient construction of the parts by virtue of which the feed-mechanism and the gauge device are mechanically associated.

In accordance with the present invention, a slicing machine of the type stated, the gauge device is positioned relatively to the slicing plane by a screw adjustment device which is mounted on the stationary base, said device consisting of a non-turnable element connected to the gauge-device and a turnable element constrained to adopt a position conforming with the slice-thickness-setting of the feed-mechanism-adjusting means.

In one construction, the gauge device is displaceable to-and-from the slicing

plane by means of a screw-connection mounted in the stationary base, the non-turnable element of said connection being connected to the gauge device and the turnable element being connected to a turnable arm in engagement with an abutment member which takes part in the adjustment of the feed-mechanism-adjusting means.

If desired, the relationship between the slice-thickness settings of the gauge device and of the feed-mechanism may be so arranged that the setting of the gauge device corresponds to a slightly greater slice-thickness than that of the feed-mechanism. With this arrangement, the thickness of the first of a series of slices (cut under the control of the feed-mechanism after the substance has been properly placed against the gauge device) is thicker than the others; but during the slicing of these others the substance moves free of the gauge device so that there can be no frictional engagement between them, with the result that the work of operating the machine is proportionately reduced.

The invention will now be described by way of example with reference to the accompanying diagrammatic drawings, in which:—

Fig. 1 is an elevation of a slicing machine of the type to which this invention relates.

Fig. 2 is a plan of Fig. 1, certain parts however being removed for clearness.

Fig. 3 is a fragmentary elevation drawn to a larger scale than Figs. 1 and 2.

Fig. 4 is a sectional plan of parts shown in Fig. 3.

Fig. 5 is a detail view in the direction of the arrow V in Fig. 3.

Fig. 6 is a sectional detail view drawn to a still larger scale of parts hereinafter described.

The slicing machine shown comprises a stationary base 10, a substance-supporting carriage 11 arranged for reciprocation upon the base 10, and a circular knife 12 is rotatably mounted in a bracket 13 secured to one side of the base 10. The reciprocatory motion of the carriage 11 and the rotary motion of the knife 12 are transmitted from a manually rota-

[Price 1/-]

Price 1/-

Price 1/-

Fig. 1.

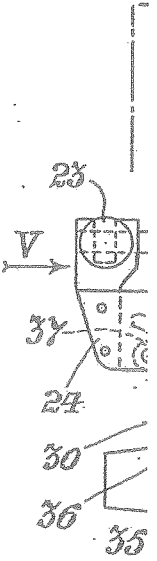
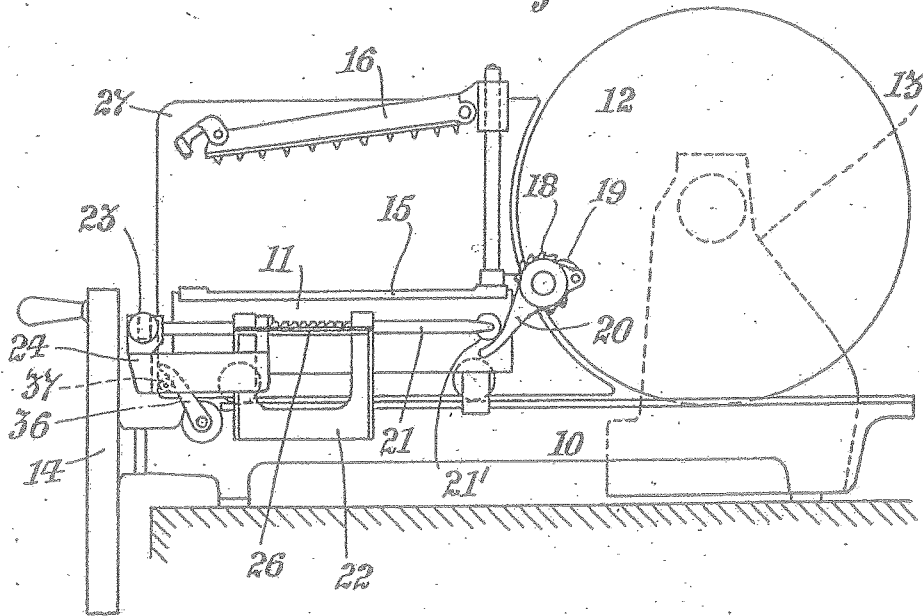
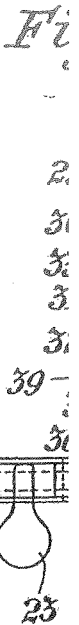
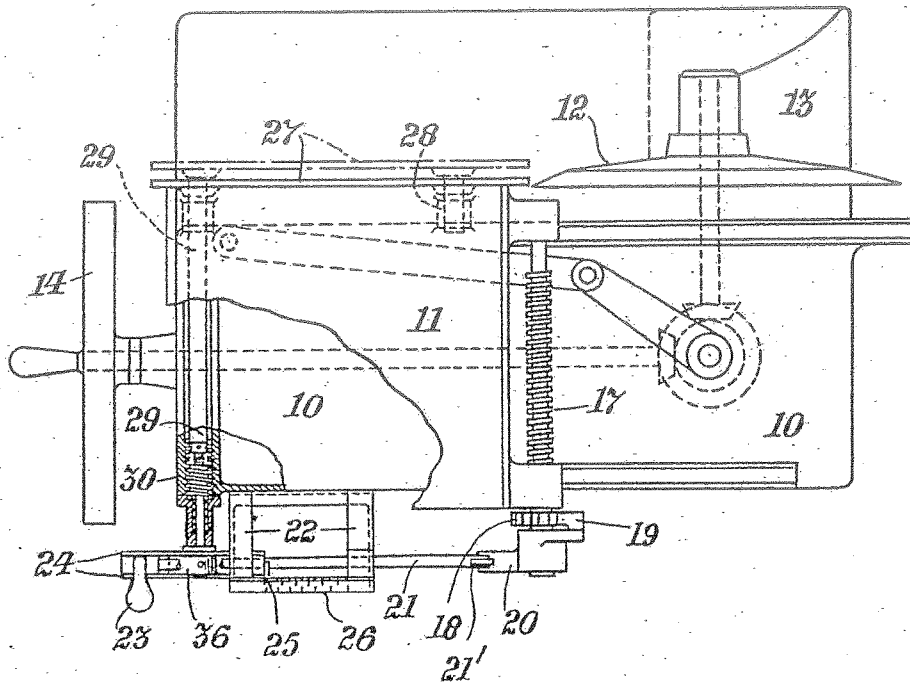

Fig. 2.



[This Drawing is a reproduction of the Original on a reduced scale.]

HEET 1

Fig. 3.

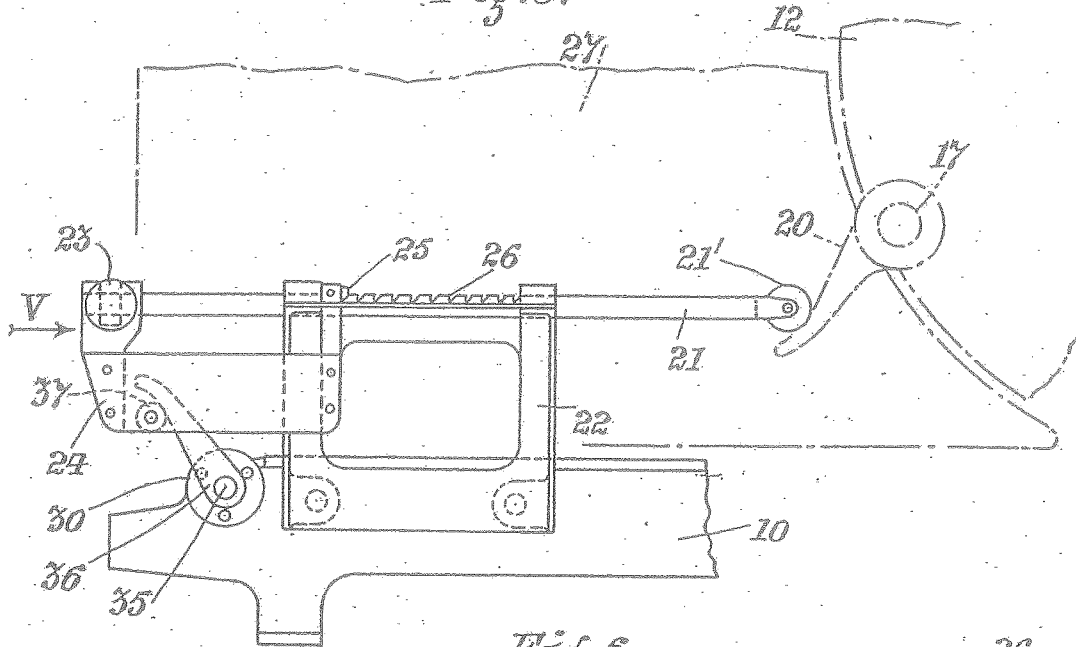

Fig. 6.

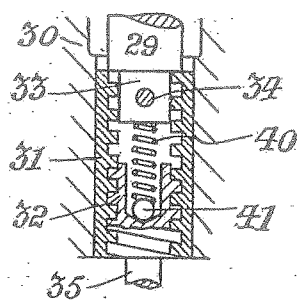

Fig. 5.

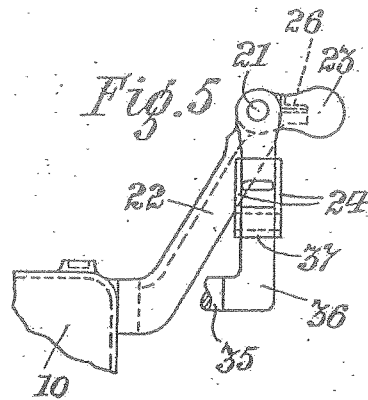
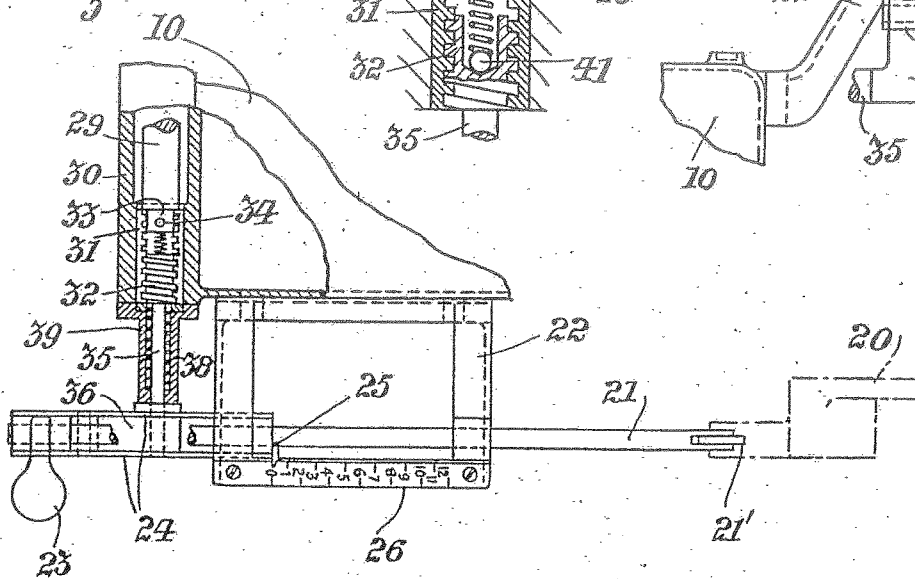

Fig. 4.



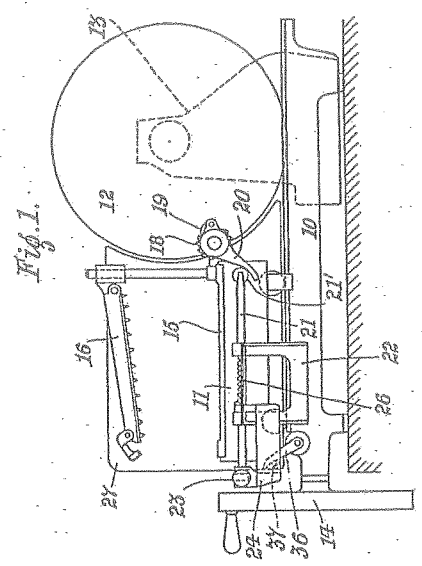

Fig. 1.

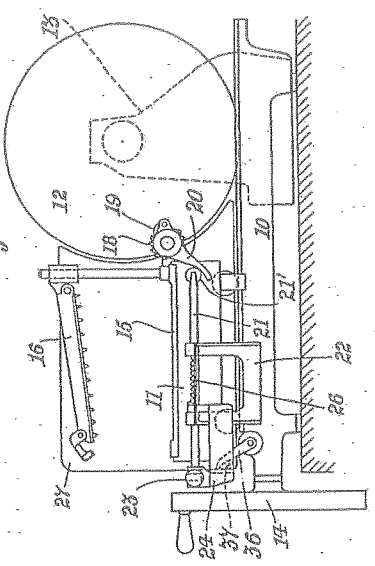

Fig. 2.

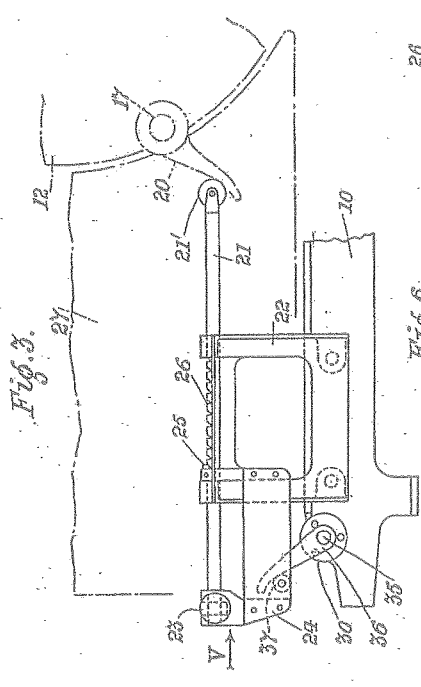

Fig. 3.

Fig. 4.

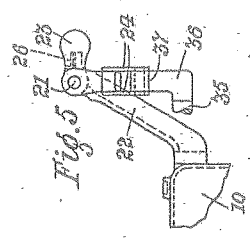

Fig. 5.

Fig. 6.

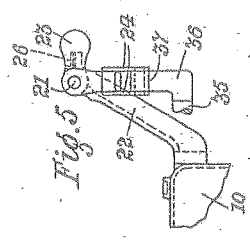
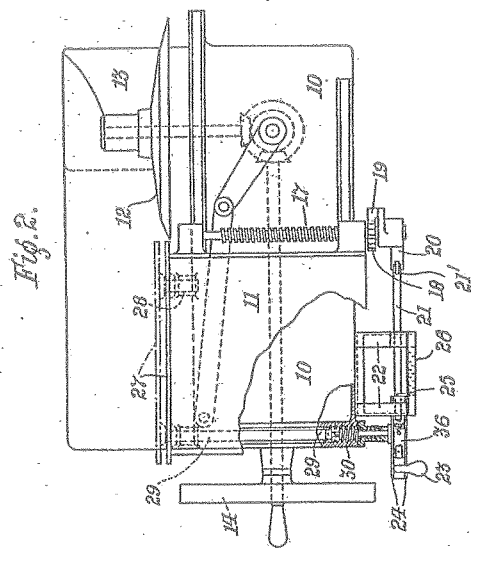

Fig. 6.



[This Drawing is a reproduction of the Original on a reduced scale.]