

PATENT SPECIFICATION

Application Date: Jan. 7, 1936. No. 537/36.

456.621

Complete Specification Left: April 24, 1936.

Complete Specification Accepted: Nov. 12, 1936.



PROVISIONAL SPECIFICATION

Improvements relating to Slicing Machines

We, BERKEL & PARNALL'S SLICING MACHINE MANUFACTURING COMPANY LIMITED, of Aden Road, Ponders End, Middlesex, England, a British Company, do hereby declare the nature of this invention, which has been communicated to us by Maatschappij van Berkel's Patent N.V. of 33 Boezemsingel, Rotterdam, Holland, a body corporate organised under the laws of Holland, to be as follows:—

This invention relates to slicing machines wherein there is provided, for determination of the slice-thickness, feed-mechanism adapted to feed the substance step-by-step across the slicing plane of the knife in the operation of the machine and, in addition, a stationary but adjustable gauge presenting an abutment face arranged beyond and parallel to the slicing plane. The arrangement is such that the gauge can be used to give accurate positioning of the substance preparatory to operation of the machine, or as an alternative to the feed-mechanism, in which latter event the substance is moved (manually or otherwise) prior to each slicing operation a step forward until it abuts against the gauge.

The invention is confined to slicing machines as above described and of the type wherein the feed-mechanism includes ratchet-and-pawl mechanism mounted on a substance-supporting carriage which is reciprocable on a stationary frame past the knife, and wherein the ratchet-and-pawl mechanism is equipped with an adjustable cam or equivalent device (hereinafter termed for convenience a "cam") for regulating the slice-thickness by lifting the pawl clear of the ratchet during a part of the pawl's stroke; i.e. the cam controls the angle of engagement of the pawl with the ratchet. The feed-movements are transmitted by a feed-screw-and-nut assembly to a feed-table or other substance-engager guided for movement across the carriage.

In accordance with the invention, the regulating cam on the reciprocatory carriage and the stationary gauge are both operatively associated with a single control member for adjusting them corre-

spondingly from a stationary location.

The single control member may consist of a hand-member which is located adjacent to the gauge and which can be set into and held in any of a series of determinate positions corresponding to different slice-thicknesses.

The regulating cam may be adjusted through the intermediary of rack-and-pinion devices, and provision may be made for holding it set, following adjustment, in any of a series of positions corresponding to the different gauge settings.

In one embodiment of the invention, the gauge consists of a plate mounted beside the knife and secured to a guide-rod slidably mounted in the stationary base constituting a part of the machine frame. The guide-rod is continuously urged by spring means to slide towards a limit position in which the gauge plate is furthest from the slicing plane; i.e. the position giving the greatest slice-thickness. The said spring means consists of a helical spring encircling the guide-rod and pressing against a collar secured thereto. The gauge-plate is constrained to adopt the desired setting, against the urge of the spring, by the control member, which consists of a stationarily fulcrumed hand-lever acting upon the guide-rod through a cam plate secured to said lever and a bellcrank lever of which one arm functions as follower to the cam plate and the other arm bears upon the aforesaid collar. The cam-following arm may be provided with a slide-block or a roller to bear upon the cam face. The arrangement is such that angular displacement of the controlling hand-lever is accompanied by proportionate displacement of the guide-rod and the gauge plate thereon.

The cam plate is secured preferably adjustably to the hand-lever. For example, the cam plate may be turnably mounted on the fulcrum of the hand-lever and secured thereto by a pin-and-slot adjustment device.

Two spaced stops, which are arranged to operate the feed-mechanism-regulating cam on the reciprocatory carriage,

[Price 1/-]

[This Drawing is a reproduction of the Original on a reduced scale.]

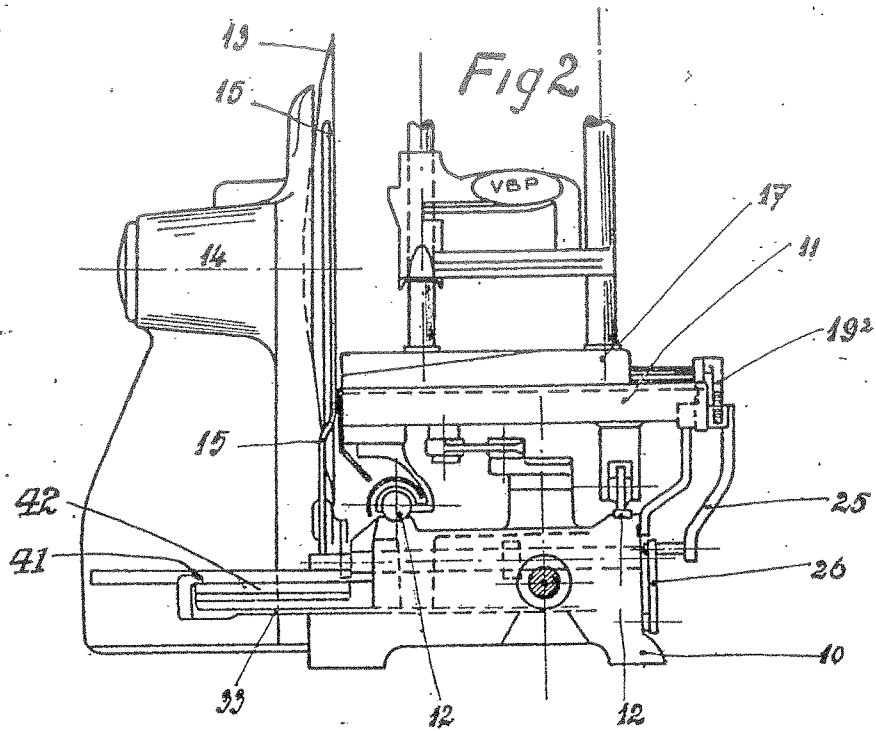
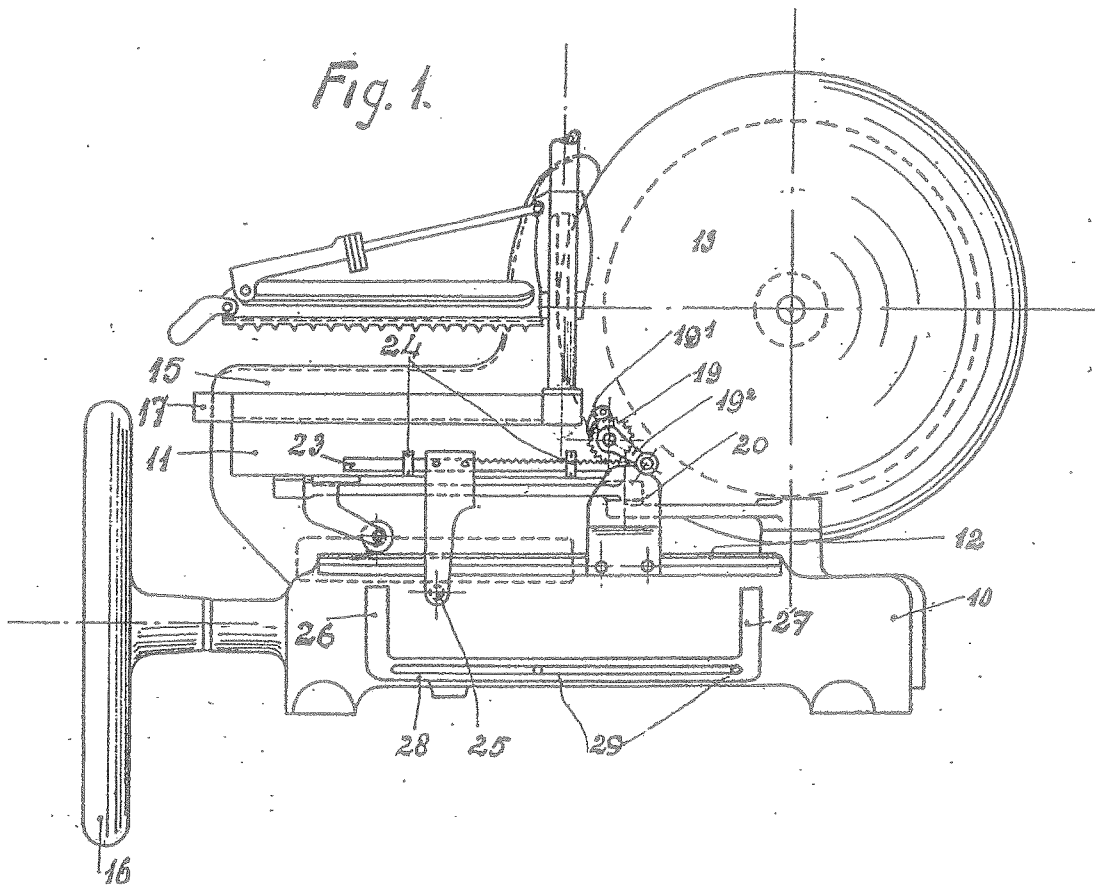

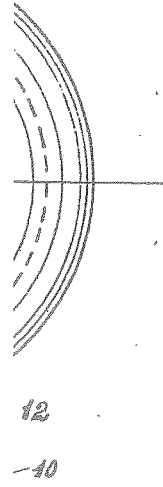
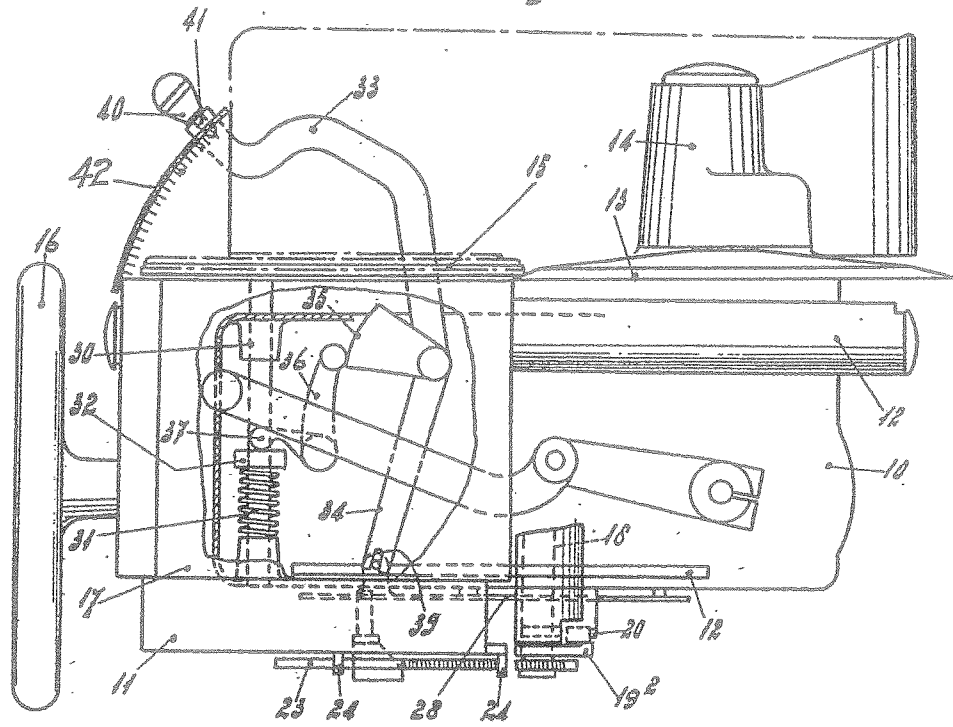

Fig. 3.



92

5

Fig. 4.

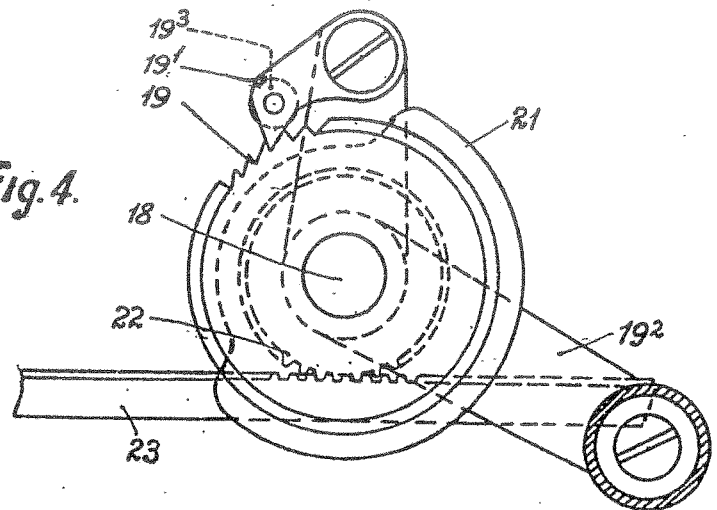

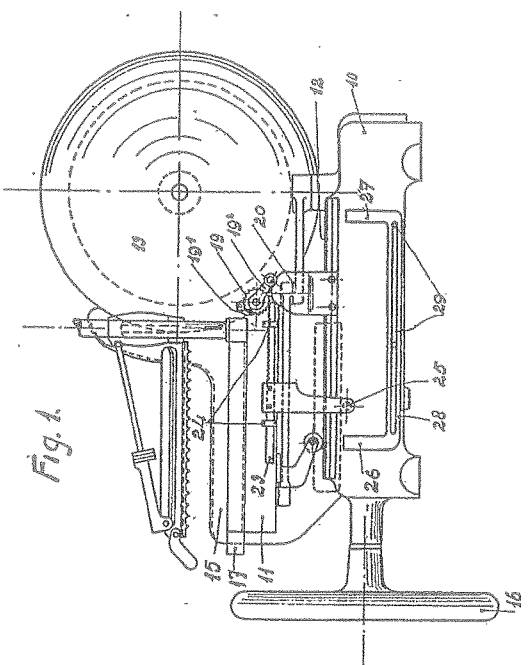

Fig. 1.

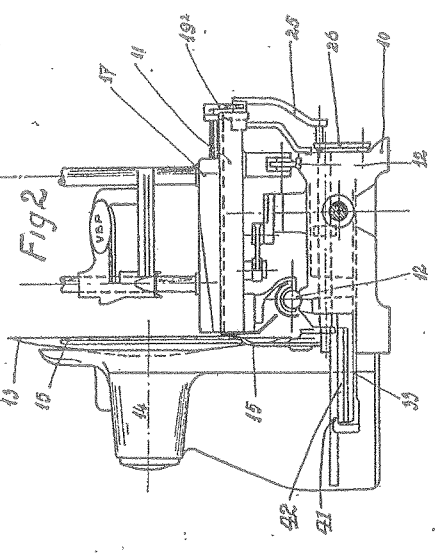
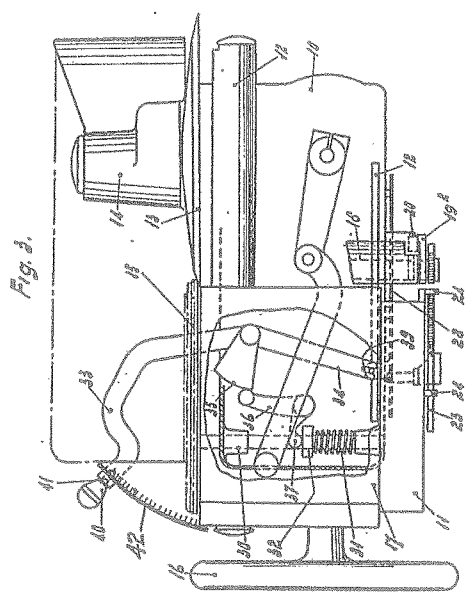

Fig. 2.

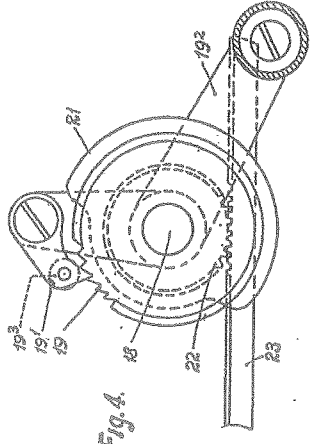

Fig. 3.

Fig. 4.

[This drawing is a reproduction of the Original on a reduced scale.]

Fig. 5.

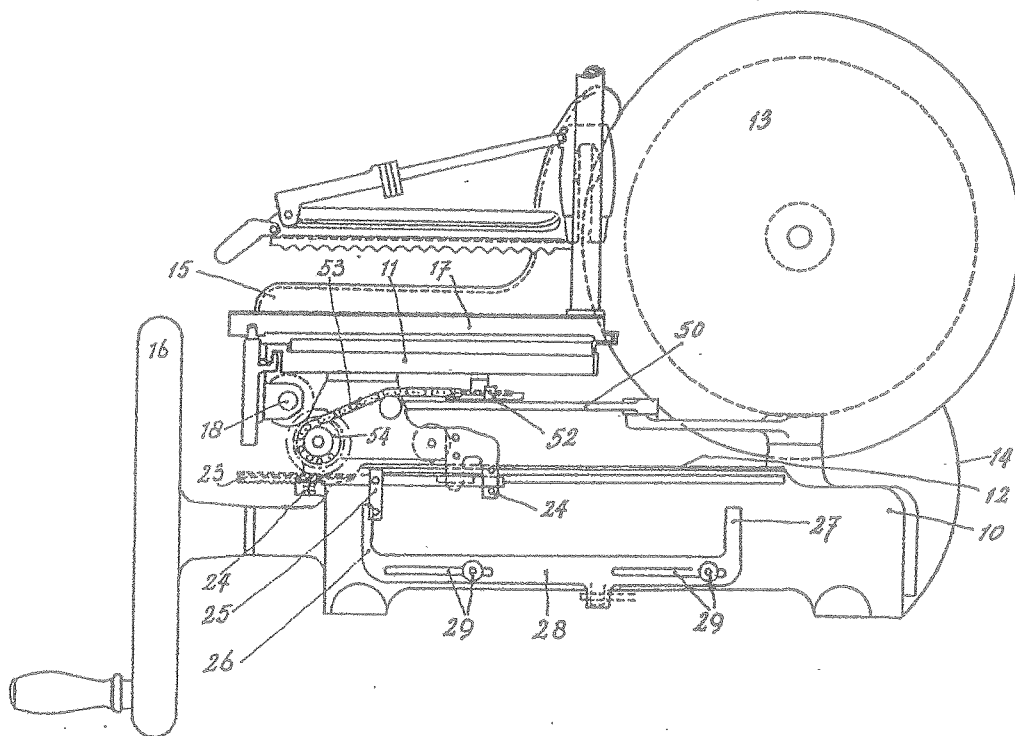
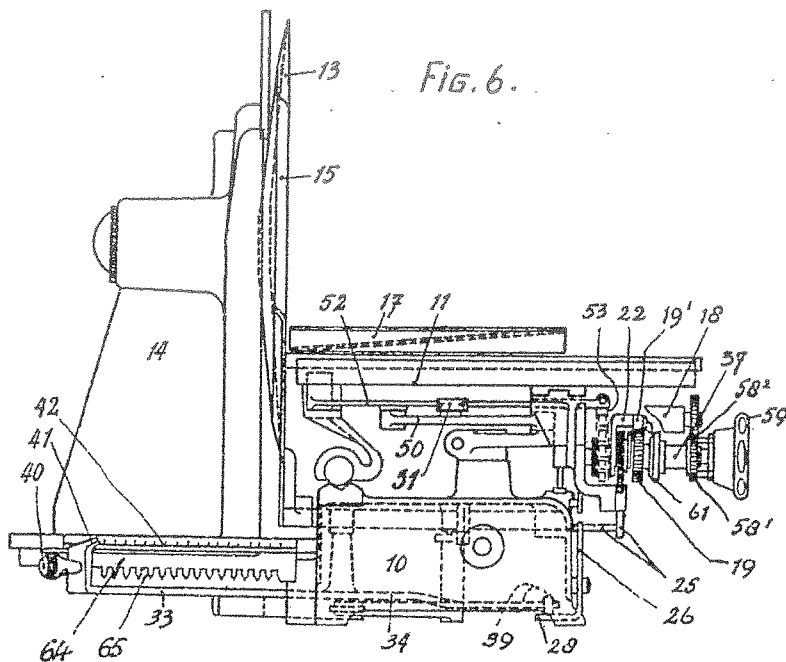

Fig. 6.



[This Drawing is a reproduction of the Original on a reduced scale.]

17

FIG. 7.

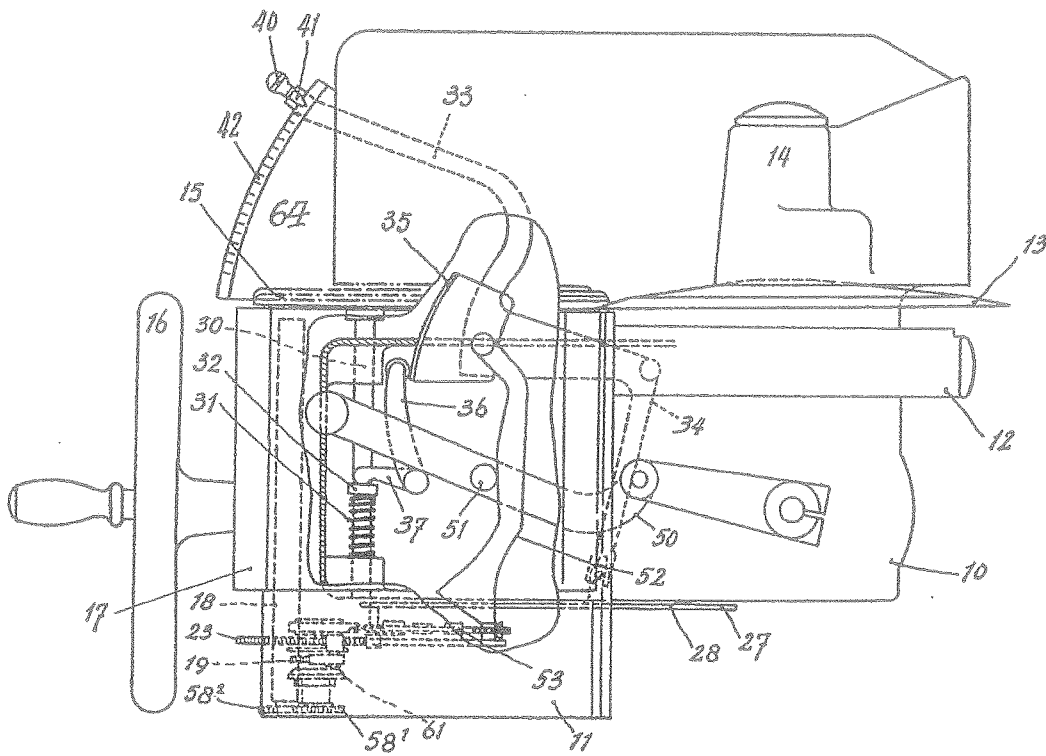

FIG. 8.

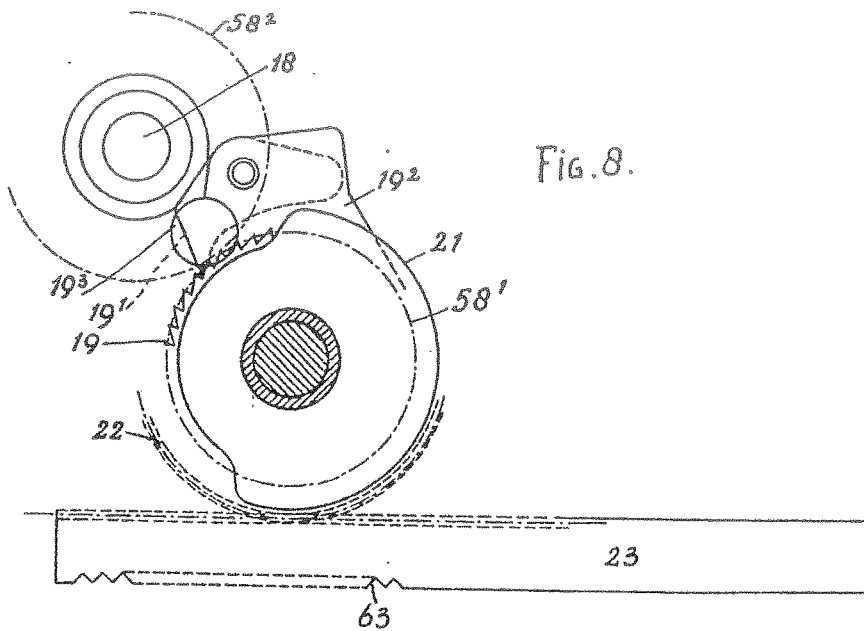

Fig. 5.

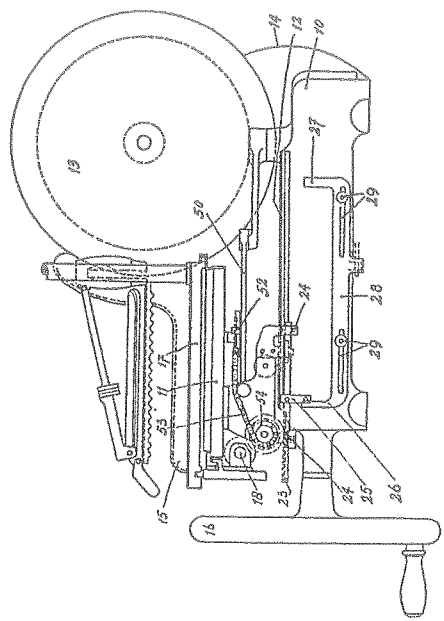

Fig. 7.

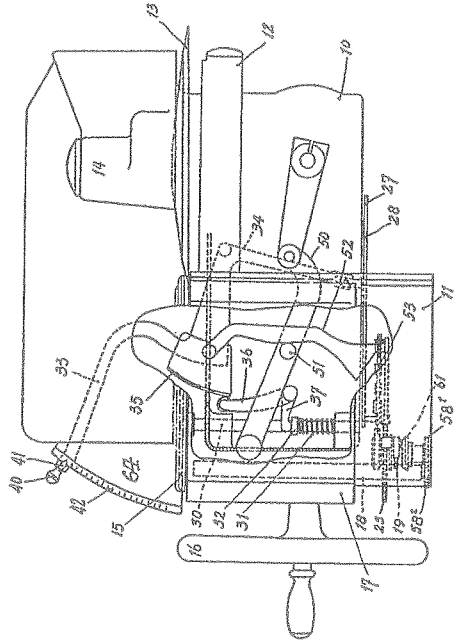

Fig. 6.

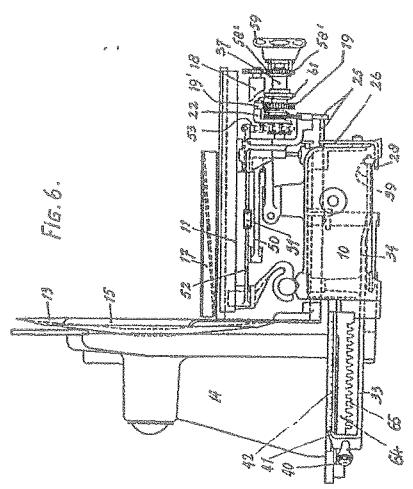
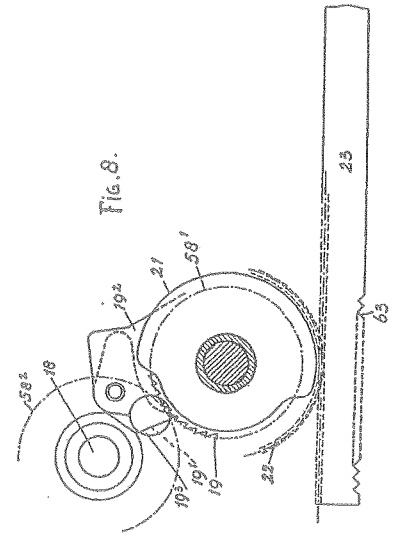
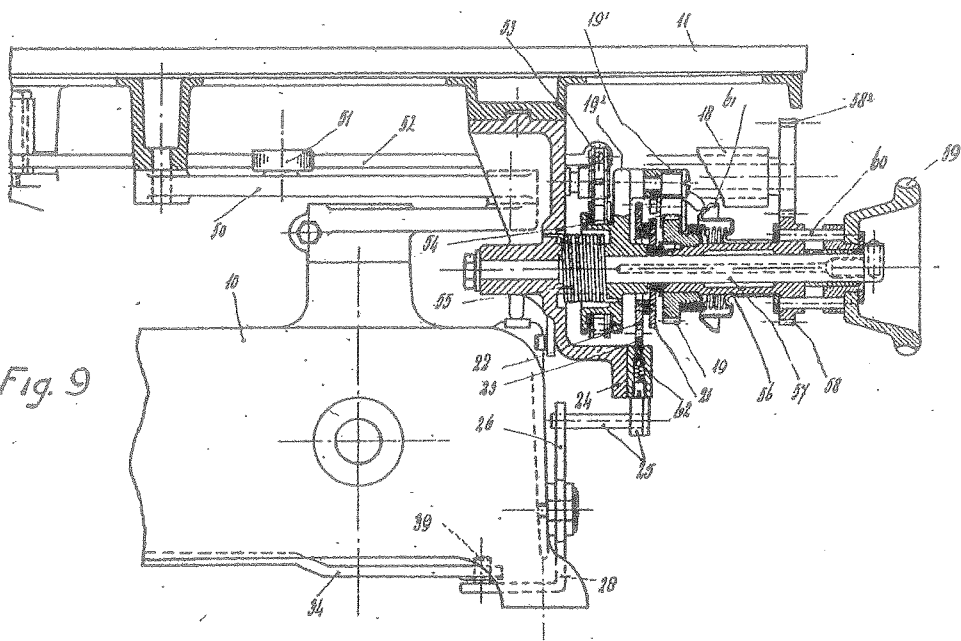

Fig. 8.



[This Drawing is a reproduction of the Original on a reduced scale.]

[This Drawing is a reproduction of the Original on a reduced scale.]



Malby & Sons Photo-Lith.