

PATENT SPECIFICATION

Convention Date (Germany) : July 21, 1933.

428,424

Application Date (in United Kingdom) : July 23, 1934. No. 21441/34.

Complete Specification Accepted : May 13, 1935.



COMPLETE SPECIFICATION

Improvements in Devices for Sharpening Knives of Slicing Machines

We, MAATSCHAPPIJ VAN BERKEL'S PATENT N.V., formerly named N.V. MAATSCHAPPIJ TOT VERVAARDIGING VAN SNIJMACHINES VOLGENS VAN BERKEL'S PATENT EN VAN ANDERE WERKTUIGEN, 33 Boezemsingel, Rotterdam, Holland, a body corporate organised under the laws of Holland, do hereby declare the nature of this invention and in what manner the same is to be performed, to be particularly described and ascertained in and by the following statement:—

Devices for sharpening the knives of slicing machines usually comprise a grinding element, which acts on one side of the circular knife edge, and a burr-removing element which acts on the other side of the knife edge to remove the burr formed by the grinding element.

This invention relates to a kind of slicing-machine-knife-sharpening device which is pivotally attached to a supporting part of the slicing machine for movement from an inoperative position into a working position, the means of attachment being such that the movement of the device to-and-from its working position takes place about an axis substantially parallel to the knife's axis of rotation.

In accordance with the invention, in a device of the kind above stated, means are provided for guiding the burr-removing element past the knife edge in the pivotal movement of the device towards the working position, and for causing said element to move into burr-removing engagement with the knife as the device moves into said position.

In a preferred construction, the positioning of the burr-removing element against the knife is effected by a camlike member connected to a supporting part of the slicing machine. Desirably, the camlike member is adjustably attached to the said supporting part.

A constructional example of a slicing-machine-knife-sharpening device according to the invention is shown diagrammatically in the accompanying drawing, in which:—

Fig. 1 is a side elevation of the device together with associated parts of the slicing machine.

Fig. 2 is a partly sectional plan of Fig. 1.

The housing 9 of the sharpening device is pivotally attached by a bolt 8 to a supporting part 7 of the slicing machine frame, the axis of the bolt 8 being substantially parallel to the axis about which the circular knife 5 rotates. A spring washer 10, or other frictional member, is interposed between the head of the bolt 8 and the bolt-embracing eye of the housing 9, the washer 10 exercising a frictional action between the housing 9 and support 7 sufficient to maintain the housing 9 in any position with respect to the knife 5.

The grinding element consists of an abrasive wheel 13 which is journaled within the housing 9. The burr-removing element consists of an abraded wheel 15 secured to a shaft 16 which is journaled in a sleeve 24, this sleeve being axially slidable but non-rotatable in the housing 9 and its axis being substantially parallel to the axes of the knife 5 and bolt 8. The arrangement is such that the wheel 15 and shaft 16 can be axially moved in unison against the pressure of a spring 19 out of the plane 18-18 of the cutting edge of the knife by means of a pin 23 projecting from the sleeve 24. A control cam 22 provided with inclines A and B is mounted fast on the aforesaid supporting part 7 of the machine frame, the cam 22 being attached to the bolt 8 by a screw 8'. The cam 22 serves for automatic positioning of the burr-removing wheel 15 against the knife edge when the housing 9 is turned into the working position. Assuming the device as a whole to be raised in the inoperative position, in which both wheels 13 and 15 are raised clear of the knife, the spring 19 maintains the wheel 15 to the maximum extent beyond the bevelled rim of the knife back. When the device as a whole is turned down about the bolt 8, the pin 23 meets the incline B of the cam 22 before the burr-removing wheel 15 reaches the knife edge. The pin 23 is then displaced by the incline B against the spring pressure, and the sleeve 24 and shaft 16 are thus forced to slide axially such an extent that the wheel 15 passes above the knife to the opposite side of the plane 18-18. Next, the pin 23 reaches the cam incline A so that the now lowered burr-removing wheel 15 is returned

[Price 1/-]

Price 4s 6d

FIG. 1

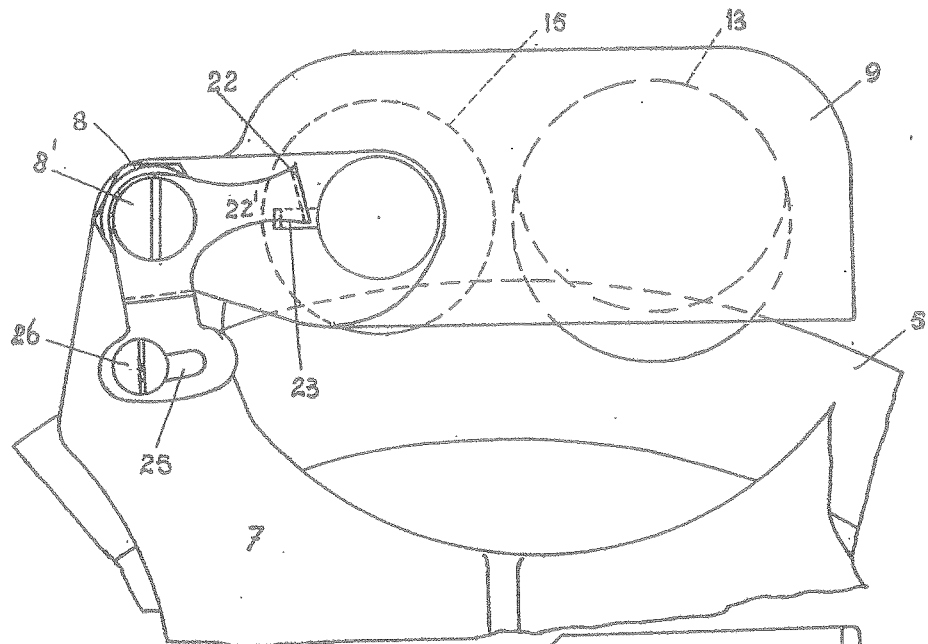
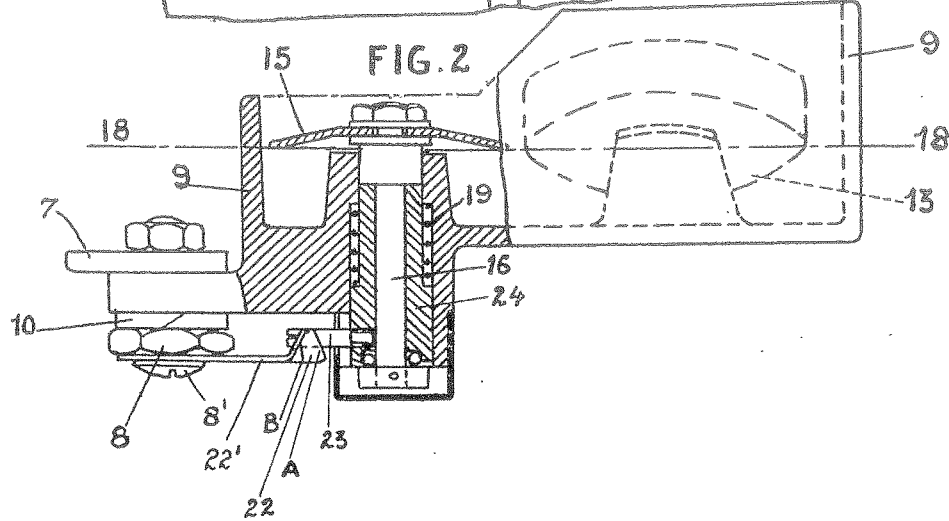

FIG. 2



*[This Drawing is a reproduction of the Original on a reduced scale.]*

Malby & Sons, Photo-Lith.